



All Rights Reserved

Materials and specifications are subject to change without notice.
Featured machines in photos may include additional equipment.
See your XCMG dealer for available options.



XE215C

Hydraulic Excavator



www.xcmg.com

XCMG Regional Departments:

Europe	(+86-516) 87739703 87739218 87739537	Africa	(+86-516) 87735009 87739222 87739283
West Asia & North Africa	(+86-516) 87739702 87739202 87739223	Central Asia	(+86-516) 87739236 87739239 87739538
Asia-Pacific	(+86-516) 87739128 87739500 87739529	America	(+86-516) 87739285 87739551 87739710

XUZHOU CONSTRUCTION MACHINERY GROUP IMP. & EXP. CO., LTD

Add: No.1, Tuolanshan Road, Xuzhou Economic Developing Zone, Jiangsu, China 221004

Fax: (+86-516) 87739230

E-mail: export@xcmg.com



Advanced Configuration

XE215C, featuring high efficiency and energy conservation, is mainly used for earth working conditions. The powerful Isuzu BB-4BG1TRP engine and high-end Kawasaki hydraulic system are matched perfectly, which can guarantee the product reliability and define high-efficiency operation and fuel economy. With strengthened structural parts, it is applicable for earth working, road construction and municipal engineering, and allow you to get digging and loading operations done easily.

Ecological and economical

- ▶ Customized high-power engine is more powerful
 - ▶ Adopting XCMG's proprietary matching technology to achieve higher operation efficiency and lower fuel consumption
- Minimized impact on emission systems and make it more environmentally friendly

Multiple applications

- ▶ Different boom, arm and bucket combinations can provide excellent all-around versatility
- ▶ Multi-functional work tool system can meet various operational requirements including digging, breaking and so on.

Comfortable operating experience

- ▶ Air conditioner and heater ensure the appropriate temperature
- ▶ Integrated control panel and large display screen provide multiple information
- ▶ Faster data management, more efficient control.
- ▶ The cab shock absorption performance is better



Excellent after-sales service

- ▶ Global after-sales service system and quick response mechanism
- ▶ Real-time technical consultation and maintenance

Convenient maintenance

- ▶ Easy maintenance design, open the engine hood for no dead angle maintenance.

Safe and durable

- ▶ Upgrade undercarriage to improve load bearing performance
- ▶ Strengthen the key stress-bearing parts of chain links
- ▶ ROPS certified cab for added safety
- ▶ Strengthen the H-beam section to greatly increase the strength of the end face

Ecological And Economical

Powerful engine

- ▶ With the original imported 128.5kW high-power engine, and XCMG's proprietary and exclusive technology, the whole machine features low-speed and high-torque, high-pressure injection, stronger power and better fuel economy. The new high-efficiency main pump is fully upgraded. With large displacement (7% larger than the previous generation), it is more efficient, less leakage under the same pressure, and with swashplate swing angle, power density can be increased and thus much more work can be done. A new generation high-efficiency main valve is featured with greater relief pressure, smaller pressure loss and more outstanding working capacity. The new safe joystick can prevent the vehicle action caused by misoperation from damaging the human body, which is safer and more reliable. The latest power matching technology, optimized fuel power curve, can save up to 7% fuel. The new type of radiator with integral brazing technology and robot welding is equipped with a positive pressure degassing expansion tank to improve the life of the pump, quickly remove the gas in the engine and waterway, reduce rust, and meet the requirements of 50 °C environment.
- ▶ Adopting XCMG's proprietary matching technology to achieve higher operation efficiency and lower fuel consumption, and the oil efficiency ratio is higher among the same class at home and abroad. The hydraulic system, after continuous optimizations and improvements, possesses higher maneuverability, which can deliver more precise control, and better leveling and loading performance.

Efficient hydraulic system

- ▶ World-renowned brand main valve features valve confluence, regeneration, priority and other functions.
- ▶ Double-pump constant-power negative-flow hydraulic system, fully absorbing engine power, has larger system flow, lower pressure loss, excellent compound operation and good economy.
- ▶ Instantaneous boost function, through the handle boost button, instantaneously improve the digging force, overcome the arduous resistance, in order to cope with complex working conditions.

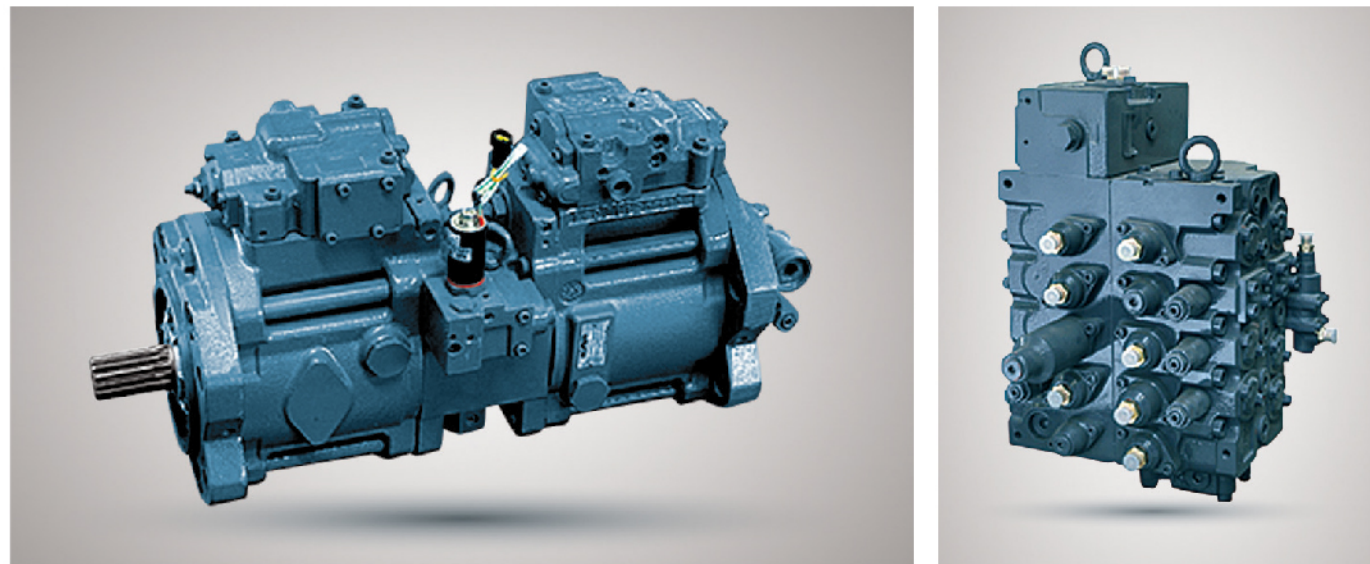

Comfortable And Reliable

Comfortable

- ▶ Spacious, comfortable and safe cab, AM/FM radio, cigarette lighter and other facilities.
- ▶ The silicone rubber spring composite damper is used to greatly reduce the vibration and impact in a certain frequency band.
- ▶ High-grade suspension woven seat is adjustable in all directions, has good ventilation, and can thus reduce the operator's fatigue.
- ▶ High-power air conditioner and heater has double-stage air filtration. The all-round stereo air outlet can realize multiple air blowing modes, which makes the operation more comfortable.



Reliable

- ▶ Forgings are used at key hinge points to greatly improve load bearing capacity and durability
- ▶ The root of the boom adopts double dovetail design to reduce stress concentration, increase the thickness of the front casting and improve the torsional bearing capacity.



- ▶ The arm adopts a box structure, and the thickness of the plate in local area is increased to improve the torsional resistance and impact resistance.

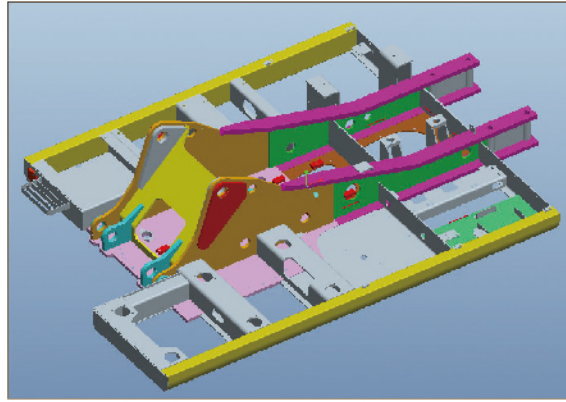

- ▶ The main beam of the turntable adopts the H-type structure, and the side beam adopts "D-section" structural steel, which has higher overall reliability.

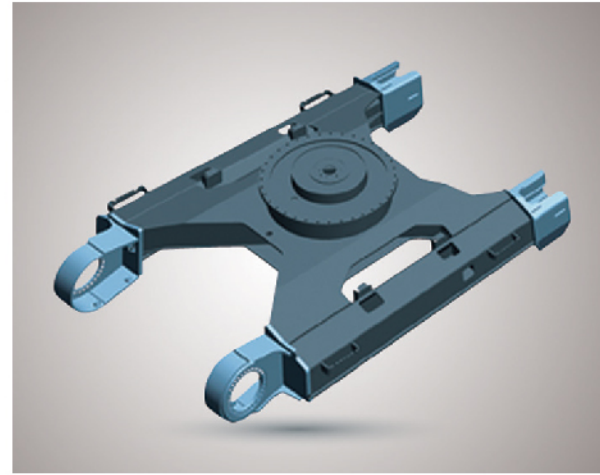

- ▶ The main beam of the turntable adopts the H-type structure, and the side beam adopts "D-section" structural steel, which has higher overall reliability.



- ▶ XCMG's self-made sprocket, idler, carrier roller, track roller and crawler, partially strengthening the track chain links, which can improve wear resistance and double the service life

- ▶ The cab seat is equipped with a seat belt; the safety lock handle is used to prevent misoperation; the fire extinguisher bracket and the safety escape hammer are arranged.



Maintenance And Service

- ▶ Open hood, all maintenance points are accessible on the ground level



- ▶ Air conditioner outer filter cleaning: open the outside cab cover with key to facilitate the cleaning of the air conditioner outer filter
- ▶ Adopt the maintenance-free air pre-filter with self-cleaning function

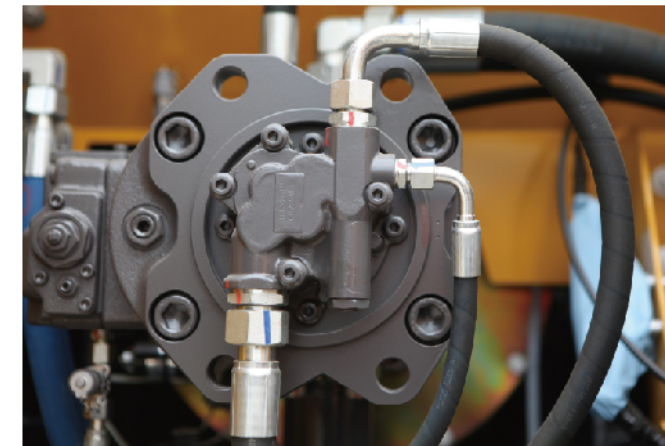

Multiple Applications Conditions

The independently developed multi-functional intelligent work tool control system can realize crushing, shearing, cleaning, compacting, milling, transporting, pinching, grasping, scraping, loosening, lifting, and other operations, and can truly integrate multiple operations into one machine.

With first-rate digging force, the machine can be fully competent under complicated working conditions.



Standard Equipment

	Name of equipment	XE215C	
Engine	Engine model	CC-6BG1TRP	
	Automatic preheating		
	Oil-water separator with water level indication sensor		
	Radial seal air cleaner		
	Air prefilter		
	50°C high temperature ambient cooling assembly		
	Radiator dust screen		
	Fuel marker		
	Oil-water quick release device		
	Fuel breather valve		
	Air pressure difference indicator		
	Automatic idle speed		
	Hydraulic system	Boom/arm flow regeneration	
		Instantaneous force	
Pilot oil filter			
Reverse rotation damping valve			
Automatic rotation parking brake			
Hydraulic buffer valve			
Straight hydraulic circuit			
Boom priority valve			
Rotary logic valve			
Hydraulic oil ISO VG 46			
Cab and interior trim	Rotary anti-sway valve		
	Gauge pressure monitoring		
	Pressurized cab		
	Fully adjustable mechanical suspension seat		

Cab and interior trim	Adjustable seat armrest	
	Seat belt (51 mm [2 "] wide)	
	Openable windscreen with auxiliary device	
	Front windshield divided by 70/30 ratio	
	Double laminated windshield and other toughened windows	
	Sliding door upper window	
	Bi-directional air outlet air conditioner with defroster (automatic type) (pressurization function)	
	Color liquid crystal display capable of displaying warning information, filter / liquid replacement information and working hours	
	Control handle	
	Travel control pedal with detachable manual control lever	
	Two stereo speakers	
	Beverage cup holder	
	Coat and hat hook	
	Cleanable floor mat	
Safety and security configuration	Air conditioning system	
	High and low gears shift	
	One-key boost mode	
	Reserve switch for working aids	
	Electric sunshade curtain	
	Top sunroof	
	Intermittent multi-gear wiper	
	Cup holder/envelope	
	Cold and warm storage box	
	Radio receiver	
Driving door locks and cabin locks		
Alarm horn		
Isolation plate between engine and oil pump chamber		
Rear window emergency exit		

	Battery circuit breaker
	Boom and arm retaining valve
	Overheat alarm
	Safety handrails and pedals
Safety and security configuration	Anti-skid plate/anti-skid paste
	Hydraulic safety locking lever
	Emergency escape hammer
	Left and right rearview mirrors
	Counterweight rearview mirror
Chassis system and shield	Bottom frame traction ring
	600 mm (24 ") three-rib track shoe
	Protective device kit: chassis bottom sealing plate, walking motor sealing plate
Working device	Boom
	Arm 2.91 m
	Bucket 1.05M ³ Strengthened Bucket
	Battery (2× 850CCA)
Electrical system	70A alternator
	7.8 kW starter motor
Lighting lamp	Right and left boom work lights
	Right working light installed on storage box
	Cab interior lighting
Technology	Intelligent control system
	Data link socket

Optional Equipment

	Name of equipment	XE215C
Engine	Oil-water separator with heater (24V)	

	Oil bath type air prefilter
Engine	Electronically controlled silicone oil clutch
	Fuel pump 50L/min
	Coolant heater (fuel type)
	Rapid fuel filling system
	Fuel filling pump 50L / min
Hydraulic system	Hydraulic line: breaker and thumb clamp
	Operation mode switching
	Spare valve
	Hydraulic oil ISO VG 32, 68
Cab and interior trim	Retractable seat belt (51 mm [2 "] wide)
	Air suspension seat with seat cushion heating
	Vehicle mounted oxygen supply device
	Fire extinguisher
	Explosion-proof valve for arm pipeline
	Roll over protective structure (ROPS)
Safety and security configuration	Counterweight rearview mirror
	Falling object protective structure (FOPS)
	Explosion-proof valve for boom pipeline
	Rotary alarm lamp
Chassis system and shield	230 mm (24 ") double-rib track shoe
	700 mm (28 ") three-rib track shoe
	800 mm (31 ") double-rib track shoe
	600 mm (24 ") three-rib track shoe
	800 mm (31 ") three-rib track shoe
	Extended chassis
	Crawler double guardrail
	Track rubber block

Chassis system and shield	Full-length track guard (two-piece, lower frame needs to be replaced)
	0.8-1.0m ³ Rock bucket
	Boom 5.2m
	Arm 2.5m
	Arm 2.4m
	0.9-1.05 m ³ Strengthen bucket
	1.0-1.3m ³ Earthwork bucket
	Quick coupler
	Hydraulic breaker
	Hydraulic thumb pliers
	Ripper
	Vibratory plate compactor
Working device	Hydraulic shear
	Grapples
	High frequency crusher
	Clamshell bucket
	Travel alarm
	Scrap grapple
	Screening bucket
	Camera
	5V USB interface
	Pipe grab
	24V cigarette lighter
	12V power interface
	Arm 2.4 m
Electrical system	Travel alarm
	Front working light installed on cab top
Lighting lamp	Rear working light installed on cab top

Lubrication system	Electric self-lubricating system
	Arm concentration

Main Specifications

Item	Unit	Parameters
Model	/	XE215C
Operating weight	Kg	21700
Bucket capacity	m ³	1.0
Engine		
Model	/	CC-6BG1TRP
Direct injection	/	√
Four strokes	/	√
Water Cooling	/	√
Turbo-charging	/	√
Air to air intercooler	/	√
No. of cylinders	/	6
Rated power/speed	kw/rpm	128.5/2100
Maximum torque/speed	N.m	637.9/1800
Displacement	L	6.494
Travel speed (H/L)	km/h	5.5/3.3
Swing speed	r/min	13.2
Gradeability	°	≤35
Ground pressure	kPa	49.1
Bucket digging force	kN	149
Arm digging force	kN	111
Maximum tractive force	kN	184
Main Performance		
Main pump	/	Two piston pump
Rated flow of main pump	L/min	2×231
Hydraulic System		
Main safety valve pressure	MPa	34.3/37

Item	unit	Main specifications
Hydraulic System	Travel system pressure	MPa 34.3
	Swing system pressure	MPa 28
	Pilot system pressure	MPa 3.9
Oil Capacity	Fuel tank capacity	L 400
	Hydraulic tank capacity	L 220
	Engine oil capacity	L 25
Standard	Length of boom	mm 5680
	Length of arm	mm 2910
	Bucket capacity	m ³ 1.0
Optional	Length of boom	mm -
	Length of arm	mm 2520
	Bucket capacity	m ³ 0.9/1.0/1.2(Earthwork bucket) 0.9/1.0(Strengthened bucket) 0.9/1.0(Rock bucket)

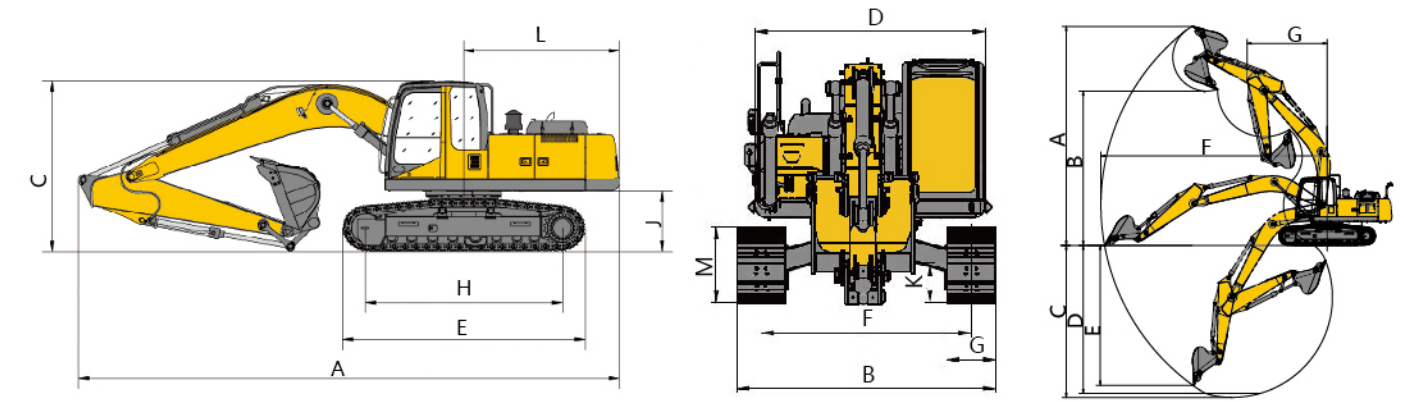

Working Range

Item	Unit	Parameters
A Max. digging height	mm	9620
B Max. dumping height	mm	6780
C Max. digging depth	mm	6680
D Maximum depth cut for 2240mm(8 ft) level bottom	mm	6320
E vertical wall digging depth	mm	5715
F Max. digging radius	mm	9940
G Min. swing radius	mm	3530

Dimensions

Item	Unit	Parameters
A Overall length	mm	9625
B Overall width	mm	2890
C Overall height	mm	2985
D Width of platform	mm	2830
E Track length	mm	4157
F Overall width of chassis	mm	2890
G Track shoe width	mm	600
H Wheel base of crawler	mm	3366
I Track gauge	mm	2290
J Counterweight clearance	mm	1050
K Min. ground clearance	mm	486
L Min. tail swing radius	mm	2844
M Track height	mm	942

Lifting Capacity

Lifting point height (m)	Rated lift capacity – Straight ahead (back) (kg)					Rated lift capacity – over-side (kg)						
	Lifting point radius (m)					Lifting capacity at maximum radius	Lifting point radius (m)					Lifting capacity at maximum radius
	1.5	3	4.5	6	7.5		1.5	3	4.5	6	7.5	
7.5				*3556.9		*2987.1				*3556.9		*2987.1
6				*3502.6		*3146.1				*3502.6		2330.1
4.5				*3994.8	*3817.2	2951.5				3942.5	2594.5	1876
3			*6268.7	*4809.1	3875.8	2661.2			6063.5	3750	2519	1658.9
1.5			*7992	5499	3792.4	2600.7			5680.9	3572.8	2441	1614.4
Ground		*4211.4	8753	5387.8	3747.1	2667.2		*4211.4	5523.4	3471.1	2398.7	1650.9
-1.5	*4854.2	*8582	8774.9	5380.6	3770.7	2982.6	*4854.2	*8582	5542.6	3464.6	2420.7	1871.7
-3	*9490.1	*12967.8	*8798.1	5484.4		3697.3	*9490.1	11752.6	5683	3559.4		2371.3
-4.5		*10582.1	7292.8			*4660.3		*10582.1	7292.8			3622.5

Capacities marked with an asterisk(*) are limited by hydraulic capacities.