



All Rights Reserved

Materials and specifications are subject to change without notice.
Featured machines in photos may include additional equipment.
See your XCMG dealer for available options.



XE370CA

Hydraulic Excavator



www.xcmg.com

XCMG Regional Departments:

Europe	(+86-516) 87739703 87739218 87739537	Africa	(+86-516) 87735009 87739222 87739283
West Asia & North Africa	(+86-516) 87739702 87739202 87739223	Central Asia	(+86-516) 87739236 87739239 87739538
Asia-Pacific	(+86-516) 87739128 87739500 87739529	America	(+86-516) 87739285 87739551 87739710

XUZHOU CONSTRUCTION MACHINERY GROUP IMP. & EXP. CO., LTD

Add: No.1, Tuolanshan Road, Xuzhou Economic Developing Zone, Jiangsu, China 221004

Fax: (+86-516) 87739230

E-mail: export@xcmg.com



Advanced Configuration

Ecological and economical

- ▶ The ISUZU engine with point-type fuel injection technology provides strong power
- ▶ The negative flow control system with double-pump confluency realizes efficient operating
- ▶ Smart electronic control system can achieve dynamic balance of power and hydraulic system

Multiple applications

- ▶ Different boom, arm and bucket combinations to maximize utilization of different conditions
- ▶ Multi-functional machine system meets various job requirements such as digging, crushing, and thumb clamp
- ▶ ESS microcomputer power control system maintains the best efficiency and economy

Comfortable operational experience

- ▶ High-performance silicone oil shock absorber improves comfort.
- ▶ Air Conditioner and Heater ensure the appropriate temperature
- ▶ Integrated control panel and large display screen provide multiple information

Excellent after-sales service

- ▶ Global after-sales service system and quick response mechanism
- ▶ Real-time technical consultation and maintenance

Convenient maintenance

- ▶ LED color display reminds you with machine maintenance information timely
- ▶ Daily maintenance points are within reach from the ground
- ▶ Dual fuel filter element can protect fuel system
- ▶ Centralized lubrication design concept makes lubrication easier

Safe and durable

- ▶ ROPS cab improves safety
- ▶ Strengthened key stress-bearing parts of chain links
- ▶ Full-size heavy-duty reinforced chassis structure can ensure the stability of the whole machine
- ▶ CAN bus communication design can effectively reduce the vehicle electrical failure rate
- ▶ 2nd generation reinforced bucket prolongs the lifespan
- ▶ The alloy work device bushing with solid graphite is more durable



Ecological And Economical

- ▶ The ISUZU engine adopts the point-type fuel injection technology and mechanical oil supply mode, which provides strong power, meets the requirements of efficient operation and reduces fuel consumption, noise and emission so as to ensure good adaptability of oil products.
- ▶ The engine speed torque curve is smooth, and low speed torque reserve is sufficient, so as to ensure that the machine is not easy to turn off and be suppressed when working at low speed. Exhaust gas supercharging technology can reduce the power loss of equipment at higher altitude.
- ▶ By adopting Kawasaki negative flow control system, and increasing the flow distribution to each actuator provided by the multi-way valve through the dual-pump confluence, so as to increase the system flow as much as possible, and deliver powerful digging force and high efficiency.
- ▶ Optimize the pressure-flow (p-q) curve of the main pump to improve operating efficiency and fuel economy.
- ▶ Control parameter modification function is added on the electronic control system, which adopts PID adjustment algorithm and adds multi-point sampling parameter adjustment to refine power adjustment in sections. Find the best matching point to fully use the engine power, achieve the balance between power and hydraulic load, and thus further reduce the fuel consumption.

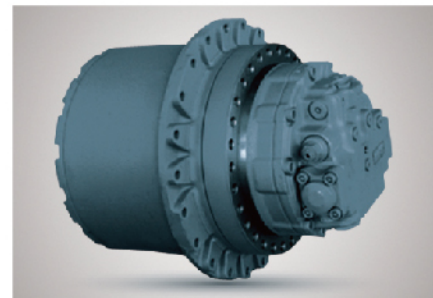
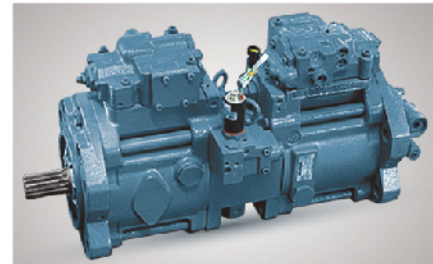
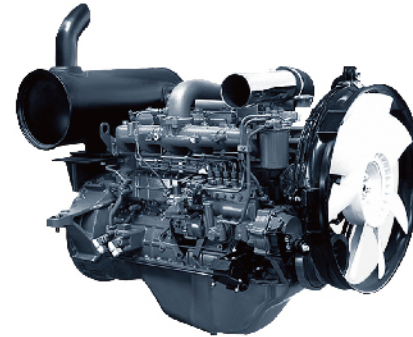

Comfortable And Safe

- ▶ High-performance silicone oil shock absorber with internal damping spring will effectively isolate shock waves in specific frequency bands for improved comfort.
- ▶ The new cab is complemented by luxurious interiors. The panoramic sunroof has a wider view and operation buttons are centrally arranged to fully upgrade the driving experience.
- ▶ Large-screen color LED display, with digital display of machine related information, has good visual effect and more human-machine interface.
- ▶ High-power air conditioner and heater, equipped with multi-channel stereo air supply system and advanced sound system, is convenient and comfortable for all kinds of operation at your fingertips.



Reliable And Durable

- ▶ With fully strengthened working equipment and high pressure system design, the machine has the most powerful digging force among the same class (bucket digging force: 263KN), which can easily meet the operation requirements under various working conditions.
- ▶ XCMG 2nd generation reinforced bucket: optimize bucket shape design, reduce chip resistance, adopt new wear-resistant material to chip blade plate. The lifespan of the bucket is 20% longer than that of the previous generation.
- ▶ The alloy work device bushing with solid graphite greatly improves the wear resistance of the machine and reduces the noise.



- ▶ Adopt a large number of special manufacturing process and high-strength and wear-resistant steel to R&D and manufacture structural parts; Strength and service life of products are greatly improved, and various severe working conditions can be easily handled.

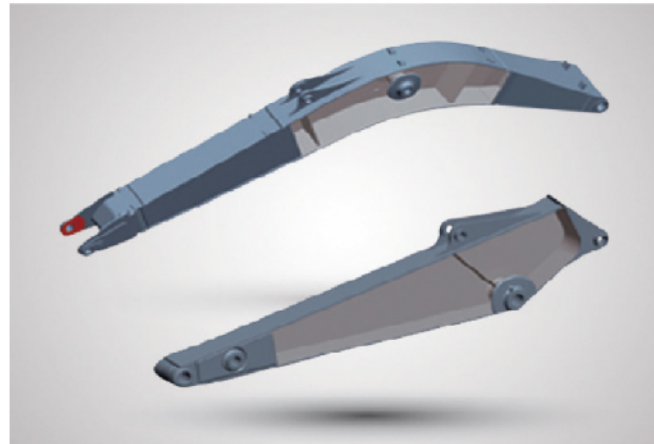
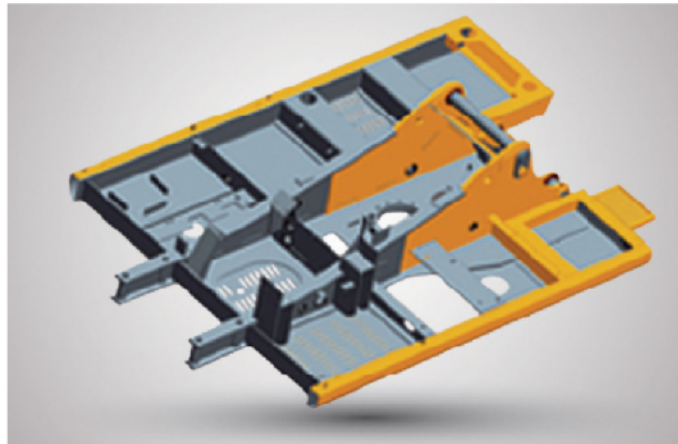

- ▶ Equipped with full-size heavy-duty reinforced chassis structure and sprocket, idler, carrier roller, track roller and track, and reinforced working equipment, it can ensure the stability of the whole machine while satisfying the powerful digging force.
- ▶ ROPS Cab can be equipped with top protection, front protection, side protection to meet anti-falling requirements, and thus to further improve cab safety.
- ▶ CAN bus communication design can effectively reduce the vehicle electrical failure rate



Maintenance And Service

- ▶ New LED color display with remote fault diagnosis function, operation process will be recorded at any time, machine maintenance will be timely reminded, which makes the users use at ease.
- ▶ Daily maintenance points are within reach: Whether it is fuel filter, oil filter, pilot filter or air filter, you can directly service it on the ground.
- ▶ The high-strength and ductile bearing bushing, assisted by the form of centralized lubrication arrangement, enables the driver operate at ease.
- ▶ Oil drain hose is added on the swing reducer, which makes the oil drain more convenient and easier.
- ▶ Oil-water separator with low resistance check valve can prevent the main pressure loss when replacing the filter.



Multiple Application Conditions

Control parameter modification function is added on the electronic control system, which adopts PID adjustment algorithm and adds multi-point sampling parameter adjustment to refine power adjustment in sections. Find the best matching point to fully use the engine power, achieve the balance between power and hydraulic load, and thus further reduce the fuel consumption. The machine can be used for digging, loading and unloading, and lifting. It can be widely used for earth working construction and mining. Its working ambient temperature ranges from -15°C to 40°C . It meets the operating requirements within 2000 meters altitude.

Hammer and quick coupler are optional, which can widen the applications of the machine. When the environment is dusty, oil bath filter is optional to extend the whole machine's service life.

Different boom, arm and bucket combinations can adapt to various working conditions.

The new ESS microcomputer power control system enables the machine to maintain the best efficiency and economy under different operating conditions. There are four working modes to choose from: H: heavy-load working mode, S: standard working mode, L: light-load working mode, B: crushing



Standard Equipment

	Name of equipment	XE370CA
Engine	Engine model	AA-6HK1XQP
	Automatic preheating	
	Oil-water separator with water level indication sensor	
	Radial seal air cleaner	
	Cooling components of 50°C high temperature environment	
	Air prefilter	
	Radiator dust screen	
	Fuel marker	
	Air pressure difference indicator	
	Automatic idle speed	
Hydraulic system	Boom/arm flow regeneration	
	Auxiliary hydraulic valve	
	Reverse rotation damping valve	
	Automatic rotation parking brake	
	Hydraulic buffer valve	
	Straight hydraulic circuit	
	Boom priority valve	
	Rotary logic valve	
	Hydraulic oil ISO VG 46	
	Rotary anti-sway valve	
Cab and interior trim	Gauge pressure monitoring	
	Pressurized cab	
	Fully adjustable mechanical suspension seat	
	Adjustable seat armrest	
	Seat belt (51 mm [2 "] wide)	
	Openable windscreen with auxiliary device	

Cab and interior trim	Double laminated windshield and other toughened windows	
	Sliding door upper window	
	Bi-directional air outlet air conditioner with defroster (automatic type) (pressurization function)	
	Color liquid crystal display capable of displaying warning information, filter / liquid replacement information and working hours	
	Control handle	
	Travel control pedal with detachable manual control lever	
	Two stereo speakers	
	Beverage cup holder	
	Coat and hat hook	
	Cleanable floor mat	
Safety and security configuration	Air conditioning system	
	High and low gears shift	
	One-key boost mode	
	Top sunroof	
	Intermittent multi-gear wiper	
	Cup holder/envelope	
	Heating and cooling storage box	
	Radio receiver	
	Driving door locks and cabin locks	
	Alarm horn	
Safety and security configuration	Isolation plate between engine and oil pump chamber	
	Emergency stop switch of engine	
	Rear window emergency exit	
	Battery circuit breaker	
	Boom and arm retaining valve	
	Overheat alarm	
	Safety handrails and pedals	
	Anti-skid plate/anti-skid paste	

Safety and security configuration	Hydraulic safety locking lever
	Emergency escape hammer
Chassis system and shield	Left and right rearview mirrors
	Bottom frame traction ring
	600 mm (24 ") three-rib track shoe
Working device	Protective device kit: chassis bottom sealing plate, walking motor sealing plate
	Boom 6.4m
	Arm 2.67m
Lamp	Bucket 1.6m ³ strengthened bucket
	Boom working lamp at left and right side
	Working lamp installed on the right side of storage box
	Lamp inside the cab
Electrical system	Front working lamp installed on the top of cab
	Battery (2×850CCA)
	50A Alternator
	5KW start motor
Counterweight	24V Cigar lighter
	7.2t Counterweight
Technology	XEICS intelligent system

Engine	Fuel breather valve
	Fast fill fuel system
Hydraulic system	Hydraulic pipeline: quartering hammer and thumb pliers
	Operating modes switch
	Hydraulic oil ISO VG 32, 68
Cab and interior trim	Spare valve disc
	Heated air suspension seat with cushion
	Retractable seat belt (51 mm [2 "] wide)
	Onboard oxygen device
Chassis system and shield	Fire extinguisher
	Reserved switch for auxiliary equipment
	Shade curtain
	600 mm (24 ") double-rib track plate
	700 mm (28 ") double-rib track plate
	800 mm (31 ") double-rib track plate
	700mm (28 ") three-rib track plate
800 mm (31 ") three-rib track plate	
Working device	Extended chassis
	Track rubber block
	Full-length track guard (two-piece, lower frame needs to be replaced)
	Boom 6.2m
	Arm 2.9m
	Arm 3.2m
	1.4-1.5m ³ Rock bucket
1.4-1.8m ³ Strengthened bucket	
1.4-1.8m ³ Earthwork bucket	
	Quick coupler
	Hydraulic breaker

Optional Equipment

	Name of equipment	XE370CA
Engine	Oil-water separator with heater (24V)	
	Oil bath type air prefilter	
	Oil and water quick discharge device	
	arm concentration	
	Fuel refueling pump 50L/min	

Working device

Hydraulic thumb pliers
Ripper
Vibratory plate compactor
Hydraulic shear
Grip
High frequency braker
Clam shell bucket
Plum-blossom shape grab bucket
Sreen-type bucket
Pipe grab machine
Travel alarm
Explosion-proof valve of boom and arm pipeline
Rotating alarm light
Counterweight reaview mirror
Falling object protective structure (FOPS)
Roll off protection structure(ROPS)
12V Cigar lighter
Camera
5V USB interface
12V Power interface
Front working lamp installed on the top of cab
Rear working lamp installed on the top of cab
200kg vice counterweight(two for options)
Electric self-lubrication system
Arm concentration lubrication

Main Specifications

Item	Unit	Parameters	
Model	/	XE370CA	
Operating weight	Kg	36600	
Bucket capacity	m ³	1.4~1.8	
Engine	Model	/ ISUZU AA-6HK1XQP	
	Direct injection	/	√
	Four strokes	/	√
	Water cooling	/	√
	Turbo-charging	/	√
	Air to air intercooler	/	√
	No. of cylinders	/	6
	Rated power/speed	kw/rpm	190.5/2000
	Maximum torque/speed	N.m	872.8/1700
	Displacement	L	7.79
Main Performance	Travel speed (H/L)	km/h	5.4/3.2
	Swing speed	r/min	9.7
	Gradeability	°	35
	Ground pressure	kPa	66.6
	Bucket digging force	kN	263
	Arm digging force	kN	225
	Maximum tractive force	kN	285
Hydraulic System	Rated flow of main pump	L/min	2×320
	Main safety valve pressure	MPa	34.3/37
	Travel system pressure	MPa	34.3
	Swing system pressure	MPa	26.5
	Pilot system pressure	MPa	3.9

Item	unit	Main specifications
Oil Capacity	Fuel tank capacity	L 630
	Hydraulic tank capacity	L 320
	Engine oil capacity	L 30
Standard	Length of boom	mm 6400
	Length of arm	mm 2670
	Bucket capacity	m ³ 1.6
Optional	Length of boom	mm 6200
	Length of arm	mm 2900
	Bucket capacity	m ³ 1.4/1.5(Rock bucket) 1.8(Earthwork bucket)

Dimensions

Item	Unit	Parameters
A Overall length	mm	11386
B Overall width	mm	3190
C Overall height	mm	3530
D Width of platform	mm	2950
E Track length	mm	5035
F Overall width of chassis	mm	3190
G Track shoe width	mm	600
H Wheel base of crawler	mm	4040
I Track gauge	mm	2590
J Counterweight clearance	mm	1197
K Min. ground clearance	mm	500
L Min. tail swing radius	mm	3570
M Track height	mm	1105

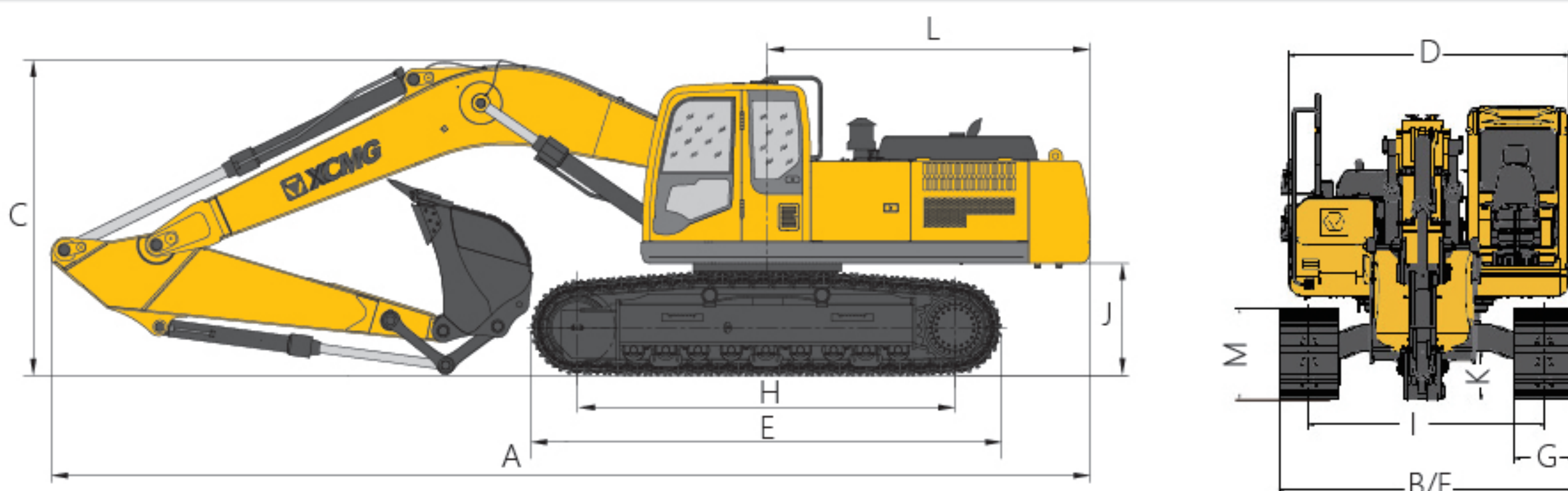

Working Range

Item	Unit	Parameters
A Max. digging height	mm	10123
B Max. dumping height	mm	6947
C Max. digging depth	mm	6927
D Maximum depth cut for 2240mm(8 ft) level bottom	mm	6709
E Max. vertical wall digging depth	mm	5312
F Max. digging radius	mm	10470
G Min. swing radius	mm	4424

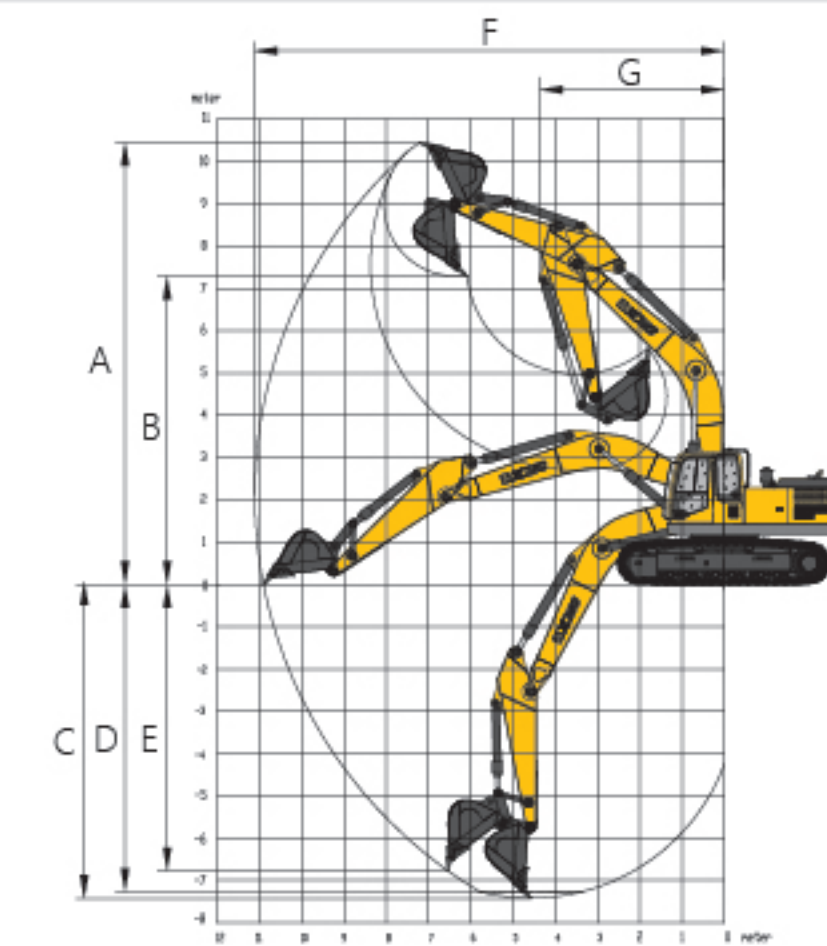

Lifting Capacity

Lifting point height (m)	Rated lift capacity – Straight ahead (back) (kg)					Rated lift capacity – over-side (kg)				
	Lifting point radius (m)				Lifting capacity at maximum radius	Lifting point radius (m)				Lifting capacity at maximum radius
	3	4.5	6	7.5		3	4.5	6	7.5	
7.5					*8759					
6			*9301	*8722	*8695			*9301	7713	6954
4.5		*13404	*10573	*9236	*8770		*13404	10260	7543	6181
3			*12055	*9953	8863			9727	7249	5791
1.5			*13280	*10615	8723			9278	6976	5647
Ground		*18702	*13851	10905	8991		13009	8943	6802	5746
-1.5	*14413	*18483	*13353	10882	*9806	24798	12951	8834	6773	6183
-3	*25586	*16449	*11171		*11064	24981	13009	8927		7146
-4.5	*20382	*13953			*12708	*20382	13450			9562

Capacities marked with an asterisk(*) are limited by hydraulic capacities.