

# SKID-STEER LOADER

## XC740K



ภายในกว้างขวาง



ง่ายต่อการบำรุงรักษา



ใช้งานได้หลากหลาย

# SKID-STEER LOADER

# XC740K

## Specifications

Rated load	750 kg
Tipping load	1500 kg
Operating weight	3140 kg
Maximum breakout force	18 kN
Bucket capacity (stacking height)	0.45 m <sup>3</sup>

## Engine

Manufacturer	Xinchai
Model	4D24G31
Rated power	49.3/36.8 Hp/kw
Rated speed	2500 rpm
Cooling mode	Water-cooling

## Performance parameter

Tire standard	10-16.5
Maximum speed	14 Km/h

## Hydraulic system

Hydraulic flow rate	62.5 L/min
Hydraulic pressure	200 bar

## Tank capacity

Diesel tank capacity	80 L
Capacity of hydraulic oil tank	60 L

## Parameters

(A) Maximum operating height	3878 mm
(B) Bucket hinge pin height	3057 mm
(C) Cabin top height	1960 mm
(D) Maximum horizontal height of bucket bottom	2851 mm
(E) Length without bucket	2533 mm
(F) Length with bucket	3310 mm
(G) Toppling angle	40°
(H) Maximum unloading height	2375 mm
(K) Ground-bucket angle	30°
(L) Rotating angle of bucket at highest point	83°
(J) Unloading distance	575 mm
(M) Wheel base	1027 mm
(O) Departure angle	25°
(P) Ground	183 mm
(R) Front radius of turning circle (without bucket)	1183 mm
(S) Front radius of turning circle (with bucket)	2066 mm
(T) Rear radius of turning circle	1564 mm
(U) Length of tail	1005 mm
(V) Wheel track	1380 mm
(W) Tire edge width	1640 mm
(X) Bucket edge width	1800 mm

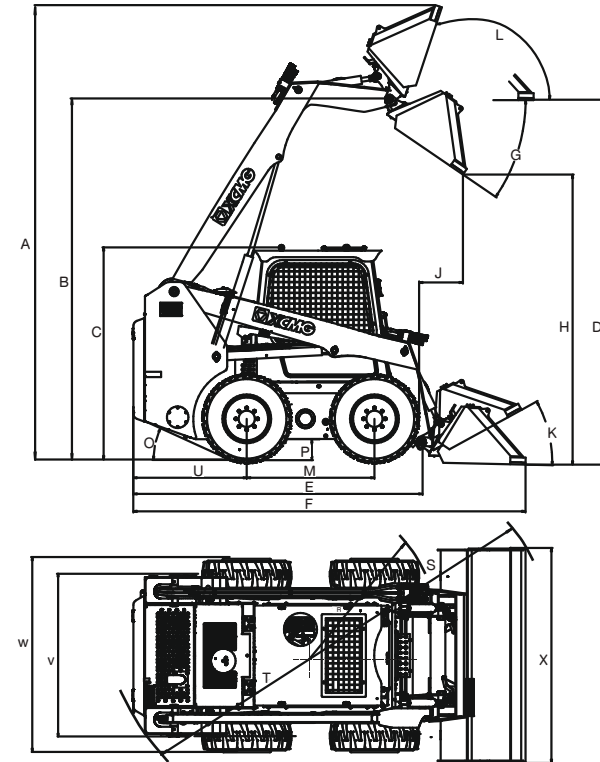

Specifications and designs are subject to change without notice.  
Machines shown may include optional equipment.



## CONTACT US:

 [www.xcmgthailand.com](http://www.xcmgthailand.com)

 [info@ocr.co.th](mailto:info@ocr.co.th)

 [@xcmg\\_thailand](https://www.instagram.com/xcmg_thailand)

 [@xcmgthailand](https://line.me/tv/@xcmgthailand)

 XCMG Thailand

 02-430-5555